



PAGE PS1

PESR™
PEERLESS
EJECTOR
SHOULDER
ROUND



PAGE PS2

PPSR™
PEERLESS
PUNCH
SHOULDER
ROUND



PAGE PS5

PERB™
PEERLESS
EJECTOR
REDUCED-SHANK
BLANKS



PAGE PS12

POBB™
PEERLESS
QUILL PUNCH
BEVEL
BLANKS



PAGE PS3

PPSP™
PEERLESS
PUNCH
SHOULDER
PARABOLIC PILOT



PAGE PS1

PESO™
PEERLESS
EJECTOR
SHOULDER
OBLONG



PAGE PS2

PPSO™
PEERLESS
PUNCH
SHOULDER
OBLONG



PAGE PS5

PPRB™
PEERLESS
PUNCH
REDUCED-SHANK
BLANKS



PAGE PS12

PQSB™
PEERLESS
QUILL PUNCH
SHOULDER
BLANKS



PAGE PS4

PPSA™
PEERLESS
PUNCH
SHOULDER
ANGULAR PILOT



PAGE PS1

PESS™
PEERLESS
EJECTOR
SHOULDER
SQUARE/RECTANGULAR



PAGE PS2

PPSS™
PEERLESS
PUNCH
SHOULDER
SQUARE/RECTANGULAR



PAGE PS6

PESB™
PEERLESS
EJECTOR
SHOULDER
BLANKS



PAGE PS13

PQBR™
PEERLESS
QUILL PUNCH
BEVEL
ROUND



PAGE PS12

PHBQ™
PEERLESS
HOLDER
BEVELED
QUILL



PAGE PS1

PESH™
PEERLESS
EJECTOR
SHOULDER
HIGH PRODUCTION



PAGE PS2

PPSH™
PEERLESS
PUNCH
SHOULDER
HIGH PRODUCTION



PAGE PS6

PPSB™
PEERLESS
PUNCH
SHOULDER
BLANKS



PAGE PS13

PQSR™
PEERLESS
QUILL PUNCH
SHOULDER
ROUND

Blank space



PAGE PS7

PBPR™
PEERLESS
BUTTON
PRESS-FIT
ROUND



PAGE PS8

PBSR™
PEERLESS
BUTTON
SHOULDER
ROUND



PAGE PS10

PGPR™
PEERLESS
GUIDE BUSHING
PRESS-FIT
ROUND



PAGE PS11

PGDR™
PEERLESS
GUIDE BUSHING
DOWNHEAD
ROUND



PAGE PS11

PGUR™
PEERLESS
GUIDE BUSHING
UPHEAD
ROUND



PAGE PS7

PBPO™
PEERLESS
BUTTON
PRESS-FIT
OBLONG



PAGE PS8

PBSO™
PEERLESS
BUTTON
SHOULDER
OBLONG



PAGE PS10

PGPO™
PEERLESS
GUIDE BUSHING
PRESS-FIT
OBLONG



PAGE PS11

PGDO™
PEERLESS
GUIDE BUSHING
DOWNHEAD
OBLONG



PAGE PS11

PGUO™
PEERLESS
GUIDE BUSHING
UPHEAD
OBLONG



PAGE PS7

PBPS™
PEERLESS
BUTTON
PRESS-FIT
SQUARE/RECTANGULAR



PAGE PS8

PBSS™
PEERLESS
BUTTON
SHOULDER
SQUARE/RECTANGULAR



PAGE PS10

PGPS™
PEERLESS
GUIDE BUSHING
PRESS-FIT
SQUARE/RECTANGULAR



PAGE PS11

PGDS™
PEERLESS
GUIDE BUSHING
DOWNHEAD
SQUARE/RECTANGULAR



PAGE PS11

PGUS™
PEERLESS
GUIDE BUSHING
UPHEAD
SQUARE/RECTANGULAR



PAGE PS7

PBPH™
PEERLESS
BUTTON
PRESS-FIT
HIGH PRODUCTION



PAGE PS8

PBSH™
PEERLESS
BUTTON
SHOULDER
HIGH PRODUCTION

Blank space



PAGE PS9

PBPB™
PEERLESS
BUTTON
PRESS-FIT
BLANK



PAGE PS9

PBSB™
PEERLESS
BUTTON
SHOULDER
BLANK

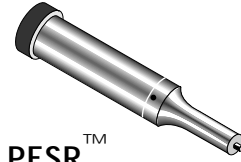
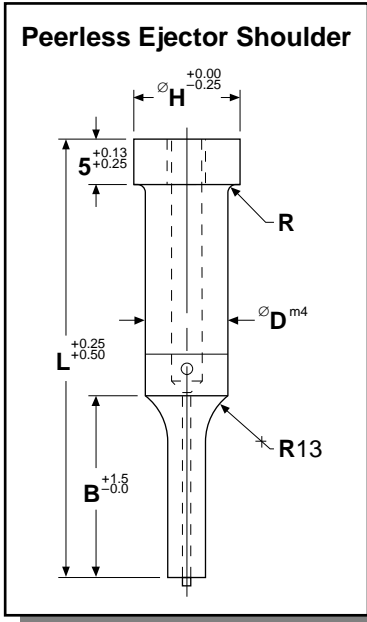

PESRTM
P
E
E
R
L
E
S
S
E
J
E
C
T
O
R
S
H
O
U
L
D
E
R
R
O
U
N
D

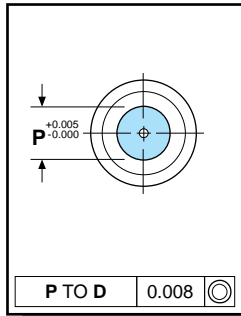

PESOTM
P
E
E
R
L
E
S
S
E
J
E
C
T
O
R
S
H
O
U
L
D
E
R
O
B
L
O
N
G

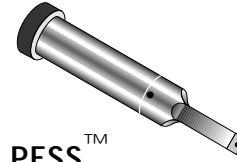
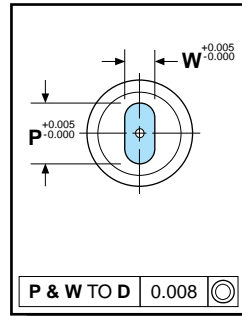

PESSTM
P
E
E
R
L
E
S
S
E
J
E
C
T
O
R
S
H
O
U
L
D
E
R
S
Q
U
A
R
E
/
R
E
C
T
A
N
G
U
L
A
R

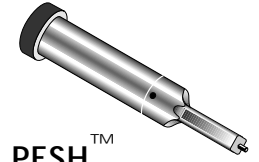
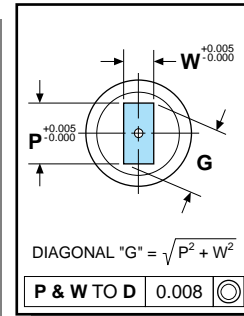

PESHTM
P
E
E
R
L
E
S
S
E
J
E
C
T
O
R
S
H
O
U
L
D
E
R
H
I
G
H
P
R
O
D
U
C
T
I
O
N

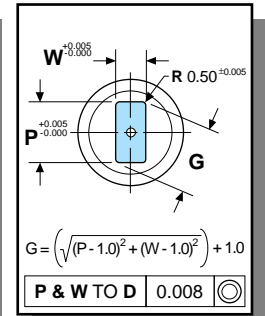

Ordering Examples:
(12) PESR 10-B50 A2 P6.3
(15) PESO 13-B50 M2 P8.7 W7.3 K3
(18) PESS 16-C63 PS P11.9 W7.8 K4
(24) PESH 20-D80 M2 P13.4 W9.4 K2

A2, R/c 59-61 double tempered
M2, R/c 61-63 triple tempered
PS, R/c 62-64 triple tempered
Heads drawn to Rc 40-55.

Key-Flats in Die Position (See Pg. T9-10)

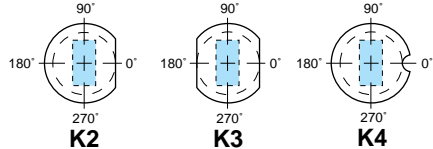

POINT LENGTH "B"	TYPE & "D"	TYPE & "D"	MIN. "P"	MIN. "W"	OVERALL LENGTH "L"									HEAD DIA. "H"	EJECT. TYPE
					32	40	45	50	56	63	71	80	90		
	A PESR 5	PES_ 5	1.6	1.6	A32	A40	A45	A50	A56	A63				8	E2AM
	A PESR 6	PES_ 6	2.4	2.4	A32	A40	A45	A50	A56	A63				9	E3M
	A PESR 8	PES_ 8	3.2	3.2	A32	A40	A45	A50	A56	A63				11	E4M
	A PESR 10	PES_ 10	4.5	4.5	A32	A40	A45	A50	A56	A63				13	E6M
	B PESR 5	PES_ 5	1.6	1.6		B40	B45	B50	B56	B63				8	E2AM
	B PESR 6	PES_ 6	2.4	2.4		B40	B45	B50	B56	B63	B71	B80		9	E3M
	B PESR 8	PES_ 8	3.2	3.2		B40	B45	B50	B56	B63	B71	B80		11	E4M
	B PESR 10	PES_ 10	4.5	4.5		B40	B45	B50	B56	B63	B71	B80		13	E6M
	B PESR 13	PES_ 13	6.0	6.0		B40	B45	B50	B56	B63	B71	B80		16	E6M
	B PESR 16	PES_ 16	8.0	7.2		B40	B45	B50	B56	B63	B71	B80		19	E9M
	B PESR 20	PES_ 20	10.0	8.0		B40	B45	B50	B56	B63	B71	B80		24	E9M
	C PESR 6	PES_ 6	2.4	2.4			C45	C50	C56	C63	C71	C80		9	E3M
	C PESR 8	PES_ 8	3.2	3.2			C45	C50	C56	C63	C71	C80		11	E4M
	C PESR 10	PES_ 10	4.5	4.5			C45	C50	C56	C63	C71	C80	C90	13	E6M
	C PESR 13	PES_ 13	6.0	6.0			C45	C50	C56	C63	C71	C80	C90	16	E6M
	C PESR 16	PES_ 16	8.0	7.2			C45	C50	C56	C63	C71	C80	C90	19	E9M
	C PESR 20	PES_ 20	10.0	8.0			C45	C50	C56	C63	C71	C80	C90	24	E9M
	D PESR 8	PES_ 8	3.2	3.2				D50	D56	D63	D71	D80		11	E4M
	D PESR 10	PES_ 10	4.5	4.5				D50	D56	D63	D71	D80	D90	13	E6M
	D PESR 13	PES_ 13	6.0	6.0				D50	D56	D63	D71	D80	D90	16	E6M
	D PESR 16	PES_ 16	8.0	7.2				D50	D56	D63	D71	D80	D90	19	E9M
	D PESR 20	PES_ 20	10.0	8.0				D50	D56	D63	D71	D80	D90	24	E9M
	D PESR 25	PES_ 25	12.8	9.0				D50	D56	D63	D71	D80	D90	29	E9M

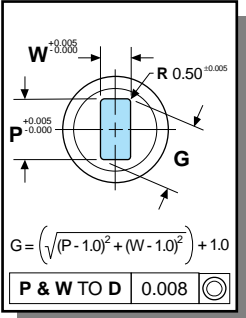
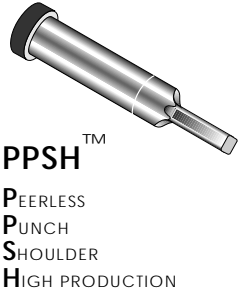
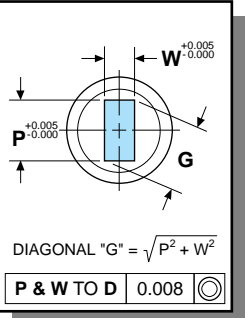
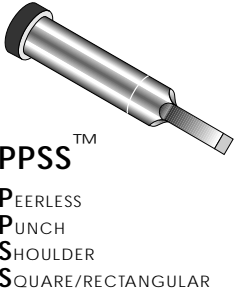
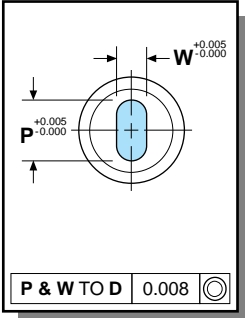
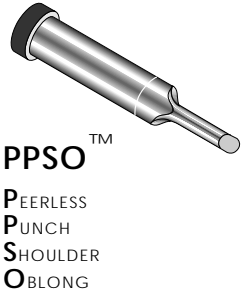
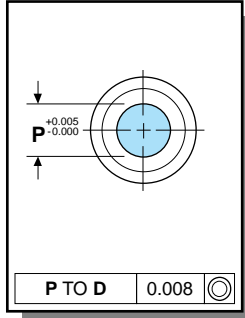
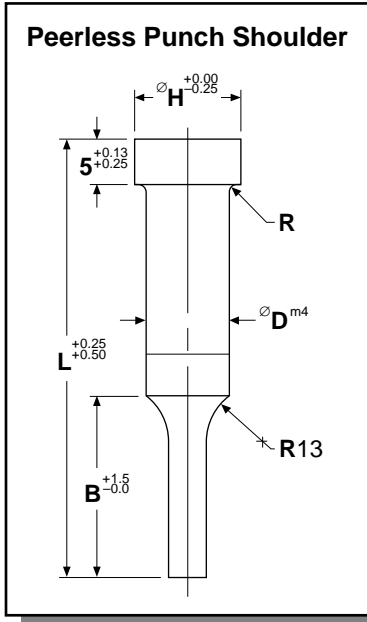

Ordering Examples:
 (4) PPSR 6-A40 A2 P3.2
 (6) PPSO 8-B56 M2 P7.4 W5.1 K4
 (8) PPSS 10-C71 M2 P8.1 W6.7 K3
 (10) PPSH 13-E63 PS P10.1 W8.9 K2

A2, R/c 59-61 double tempered
 M2, R/c 61-63 triple tempered
 PS, R/c 62-64 triple tempered
 Heads drawn to Rc 40-55.

Key-Flats in Die Position (See Pg. T9-10)

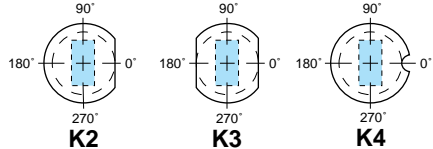

POINT LENGTH "B"	TYPE & "D"	TYPE & "D"	MIN. "P"	MIN. "W"	OVERALL LENGTH "L"								HEAD DIA. "H"	
					32	40	45	50	56	63	71	80		90
13.0	PPSR 4	PPS_ 4	1.5	1.5	A32	A40	A45	A50	A56	A63				7
	PPSR 5	PPS_ 5	1.5	1.5	A32	A40	A45	A50	A56	A63				8
	PPSR 6	PPS_ 6	1.5	1.5	A32	A40	A45	A50	A56	A63				9
	PPSR 8	PPS_ 8	2.5	2.5	A32	A40	A45	A50	A56	A63				11
	PPSR 10	PPS_ 10	4.0	3.2	A32	A40	A45	A50	A56	A63				13
20.0	PPSR 4	PPS_ 4	1.6	1.6		B40	B45	B50	B56	B63				7
	PPSR 5	PPS_ 5	1.6	1.6		B40	B45	B50	B56	B63	B71			8
	PPSR 6	PPS_ 6	1.6	1.6		B40	B45	B50	B56	B63	B71	B80		9
	PPSR 8	PPS_ 8	2.5	2.5		B40	B45	B50	B56	B63	B71	B80		11
	PPSR 10	PPS_ 10	4.0	3.2		B40	B45	B50	B56	B63	B71	B80		13
	PPSR 13	PPS_ 13	6.0	5.0		B40	B45	B50	B56	B63	B71	B80		16
	PPSR 16	PPS_ 16	8.0	6.0		B40	B45	B50	B56	B63	B71	B80		19
	PPSR 20	PPS_ 20	10.0	8.0		B40	B45	B50	B56	B63	B71	B80		24
25.0	PPSR 4	PPS_ 4	1.6	1.6				C45	C50	C56	C63			7
	PPSR 5	PPS_ 5	1.6	1.6				C45	C50	C56	C63	C71		8
	PPSR 6	PPS_ 6	1.6	1.6				C45	C50	C56	C63	C71	C80	9
	PPSR 8	PPS_ 8	2.5	2.5				C45	C50	C56	C63	C71	C80	11
	PPSR 10	PPS_ 10	4.0	3.2				C45	C50	C56	C63	C71	C80	13
	PPSR 13	PPS_ 13	6.0	5.0				C45	C50	C56	C63	C71	C80	16
	PPSR 16	PPS_ 16	8.0	6.0				C45	C50	C56	C63	C71	C80	19
	PPSR 20	PPS_ 20	10.0	8.0				C45	C50	C56	C63	C71	C80	24
	PPSR 25	PPS_ 25	12.8	9.0				C45	C50	C56	C63	C71	C80	29
32.0	PPSR 4	PPS_ 4	2.5	2.5				D50	D56	D63				7
	PPSR 5	PPS_ 5	2.5	2.5				D50	D56	D63	D71			8
	PPSR 6	PPS_ 6	2.5	2.5				D50	D56	D63	D71	D80		9
	PPSR 8	PPS_ 8	2.5	2.5				D50	D56	D63	D71	D80		11
	PPSR 10	PPS_ 10	4.0	3.2				D50	D56	D63	D71	D80	D90	13
	PPSR 13	PPS_ 13	6.0	5.0				D50	D56	D63	D71	D80	D90	16
	PPSR 16	PPS_ 16	8.0	6.0				D50	D56	D63	D71	D80	D90	19
	PPSR 20	PPS_ 20	10.0	8.0				D50	D56	D63	D71	D80	D90	24
38.0	PPSR 5	PPS_ 5	3.2	3.2					E56	E63	E71			8
	PPSR 6	PPS_ 6	3.2	3.2					E56	E63	E71	E80		9
	PPSR 8	PPS_ 8	3.2	3.2					E56	E63	E71	E80		11
	PPSR 10	PPS_ 10	4.0	3.2					E56	E63	E71	E80	E90	13
	PPSR 13	PPS_ 13	6.0	5.0					E56	E63	E71	E80	E90	16
	PPSR 16	PPS_ 16	8.0	6.0					E56	E63	E71	E80	E90	19
	PPSR 20	PPS_ 20	10.0	8.0					E56	E63	E71	E80	E90	24
	PPSR 25	PPS_ 25	12.8	9.0					E56	E63	E71	E80	E90	29

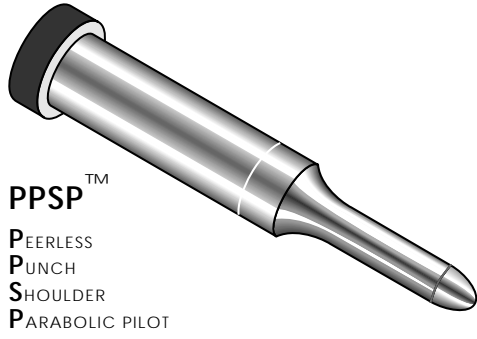

Lane Parabolic Pilots are recommended for light-gage, high-speed applications.

The polished parabolic point (lead) reduces friction, resulting in longer wear, less part distortion and improved stamping quality.

A2, R/c 59-61 double tempered
M2, R/c 61-63 triple tempered
PS, R/c 62-64 triple tempered
Heads drawn to Rc 40-55.

Ordering Example:
(12) PPSP 10-B63 M2 P8.7

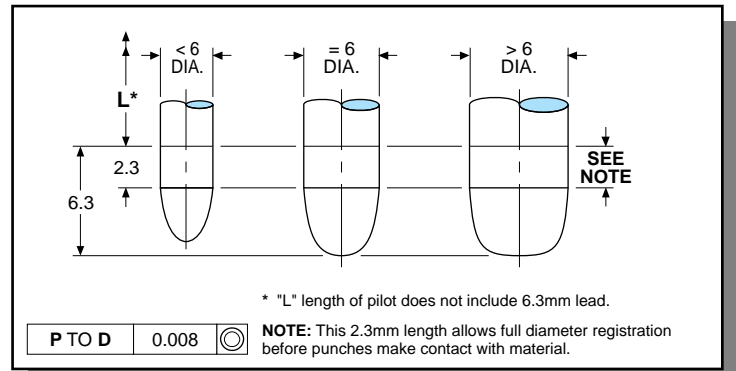
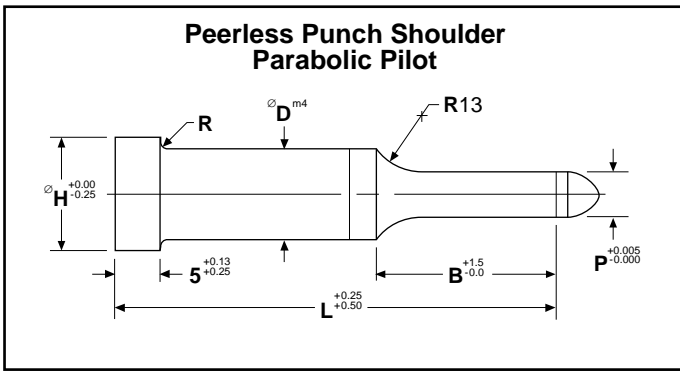

POINT LENGTH "B"	TYPE & "D"	MIN. "P"	LENGTH "L"									HEAD DIA. "H"
			32	40	45	50	56	63	71	80	90	
A 13.0	PPSP 4	1.45	A32	A40	A45	A50	A56	A63				7
	PPSP 5	1.45	A32	A40	A45	A50	A56	A63				8
	PPSP 6	1.45	A32	A40	A45	A50	A56	A63				9
	PPSP 8	2.35	A32	A40	A45	A50	A56	A63				11
	PPSP 10	3.95	A32	A40	A45	A50	A56	A63				13
B 20.0	PPSP 4	1.55		B40	B45	B50	B56	B63				7
	PPSP 5	1.55		B40	B45	B50	B56	B63	B71			8
	PPSP 6	1.55		B40	B45	B50	B56	B63	B71	B80		9
	PPSP 8	2.35		B40	B45	B50	B56	B63	B71	B80		11
	PPSP 10	3.95		B40	B45	B50	B56	B63	B71	B80		13
	PPSP 13	5.95		B40	B45	B50	B56	B63	B71	B80		16
	PPSP 16	7.95		B40	B45	B50	B56	B63	B71	B80		19
C 25.0	PPSP 4	2.35			C45	C50	C56	C63				7
	PPSP 5	2.35			C45	C50	C56	C63	C71			8
	PPSP 6	2.35			C45	C50	C56	C63	C71	C80		9
	PPSP 8	2.35			C45	C50	C56	C63	C71	C80		11
	PPSP 10	3.95			C45	C50	C56	C63	C71	C80	C90	13
	PPSP 13	5.95			C45	C50	C56	C63	C71	C80	C90	16
	PPSP 16	7.95			C45	C50	C56	C63	C71	C80	C90	19
D 32.0	PPSP 5	3.15				D50	D56	D63	D71			8
	PPSP 6	3.15				D50	D56	D63	D71	D80		9
	PPSP 8	3.15				D50	D56	D63	D71	D80		11
	PPSP 10	3.95				D50	D56	D63	D71	D80	D90	13
	PPSP 13	5.95				D50	D56	D63	D71	D80	D90	16
	PPSP 16	7.95				D50	D56	D63	D71	D80	D90	19
	PPSP 20	9.95				D50	D56	D63	D71	D80	D90	24
PPSP 25	12.75				D50	D56	D63	D71	D80	D90	29	

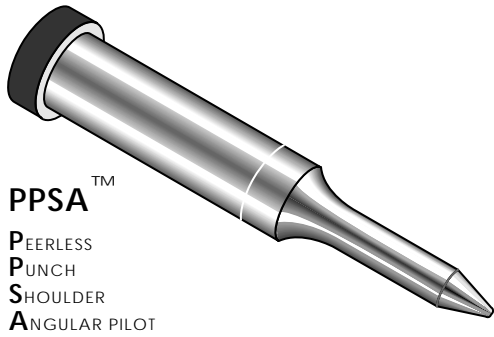

PPSA™
PEEERLESS
PUNCH
SHOULDER
ANGULAR PILOT

Lane Angular Pilots provide greater positioning (movement) of stock than do conventional pilots.

Angular pilots are recommended for the large panel and transfer dies common to the automotive and major appliance industries.

A2, R/c 59-61 double tempered
 M2, R/c 61-63 triple tempered
 PS, R/c 62-64 triple tempered
 Heads drawn to Rc 40-55.

Ordering Example:
(6) PPSA 16-D80 M2 P11.1

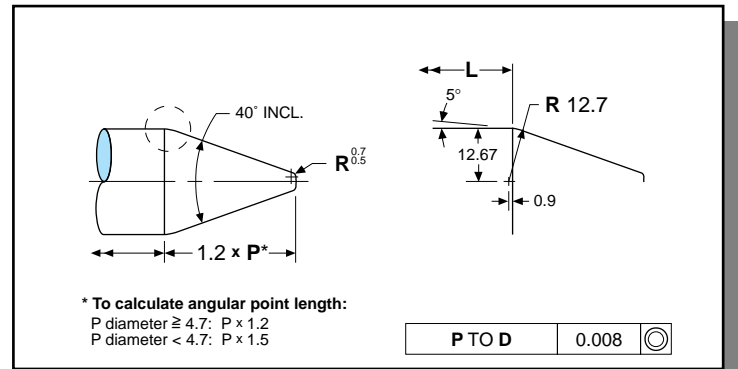
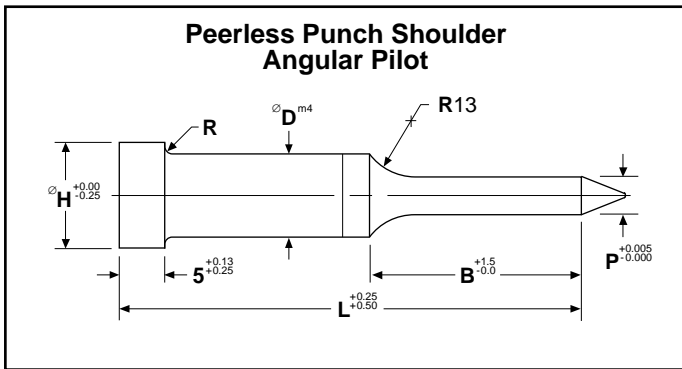

POINT LENGTH "B"	TYPE & "D"	MIN. "P"	LENGTH "L"								HEAD DIA. "H"
			63	71	80	90	100	110	125	140	
A 13.0	PPSA 4	1.45	A63	A71							7
	PPSA 5	1.45	A63	A71							8
	PPSA 6	1.45	A63	A71	A80						9
	PPSA 8	2.35	A63	A71	A80	A90					11
	PPSA 10	3.95	A63	A71	A80	A90	A100	A110			13
B 20.0	PPSA 4	1.55	B63	B71							7
	PPSA 5	1.55	B63	B71							8
	PPSA 6	1.55		B71	B80						9
	PPSA 8	2.35		B71	B80	B90					11
	PPSA 10	3.95		B71	B80	B90	B100	B110			13
	PPSA 13	5.95		B71	B80	B90	B100	B110	B125		16
	PPSA 16	7.95		B71	B80	B90	B100	B110	B125	B140	19
	PPSA 20	9.95		B71	B80	B90	B100	B110	B125	B140	24
C 25.0	PPSA 4	2.35		C71							7
	PPSA 5	2.35		C71							8
	PPSA 6	2.35		C71	C80						9
	PPSA 8	2.35			C80	C90					11
	PPSA 10	3.95			C80	C90	C100	C110			13
	PPSA 13	5.95			C80	C90	C100	C110	C125		16
	PPSA 16	7.95			C80	C90	C100	C110	C125	C140	19
	PPSA 20	9.95			C80	C90	C100	C110	C125	C140	24
	PPSA 25	12.75			C80	C90	C100	C110	C125	C140	29
D 32.0	PPSA 5	3.15		D71							8
	PPSA 6	3.15		D71	D80						9
	PPSA 8	3.15			D80	D90					11
	PPSA 10	3.95				D90	D100	D110			13
	PPSA 13	5.95				D90	D100	D110	D125		16
	PPSA 16	7.95				D90	D100	D110	D125	D140	19
	PPSA 20	9.95				D90	D100	D110	D125	D140	24
	PPSA 25	12.75				D90	D100	D110	D125	D140	29

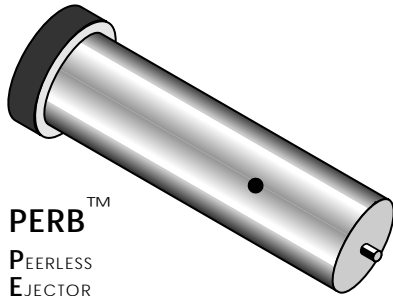

PERB™
P
E
E
R
L
E
S
S
E
J
E
C
T
O
R
R
E
D
U
C
E
D
-
S
H
A
N
K
B
L
A
N
K
S

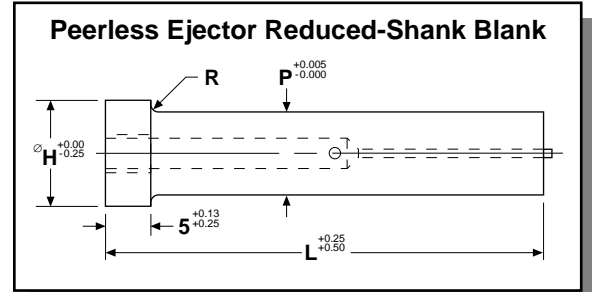

A2, R/c 59-61 double tempered
M2, R/c 61-63 triple tempered
PS, R/c 62-64 triple tempered

Heads drawn to Rc 40-55.

Ordering Example:
(18) PERB 10-56 M2 P8.3

TYPE	"P"	OVERALL LENGTH "L"									HEAD DIA. "H"	EJECT. TYPE
		32	40	45	50	56	63	71	80	90		
PERB 6	5.00 – 6.00	32	40	45	50	56					9	E3M
PERB 8	6.01 – 8.00	32	40	45	50	56	63	71	80		11	E4M
PERB 10	8.01 – 10.00	32	40	45	50	56	63	71	80	90	13	E6M
PERB 13	10.01 – 13.00		40	45	50	56	63	71	80	90	16	E6M
PERB 16	13.01 – 16.00		40	45	50	56	63	71	80	90	19	E9M

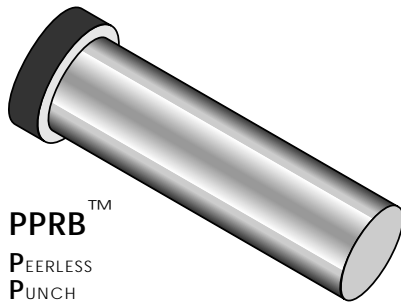

PPRB™
P
E
E
R
L
E
S
S
P
U
N
C
H
R
E
D
U
C
E
D
-
S
H
A
N
K
B
L
A
N
K
S

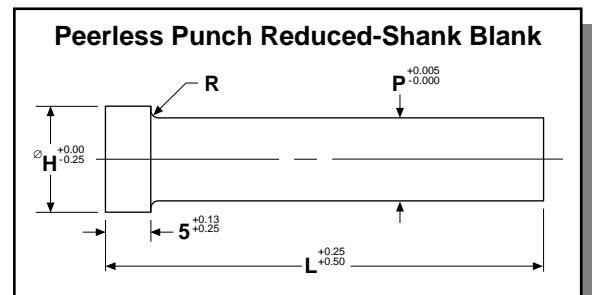

A2, R/c 59-61 double tempered
M2, R/c 61-63 triple tempered
PS, R/c 62-64 triple tempered

Heads drawn to Rc 40-55.

Ordering Example:
(21) PPRB 5-40 PS P4.3

TYPE	"P"	OVERALL LENGTH "L"									HEAD DIA. "H"
		32	40	45	50	56	63	71	80	90	
PPRB 4	3.00 – 4.00	32	40	45	50	56	63				7
PPRB 5	4.01 – 5.00	32	40	45	50	56	63	71			8
PPRB 6	5.01 – 6.00	32	40	45	50	56	63	71	80		9
PPRB 8	6.01 – 8.00	32	40	45	50	56	63	71	80		11
PPRB 10	8.01 – 10.00	32	40	45	50	56	63	71	80	90	13
PPRB 13	10.01 – 13.00	32	40	45	50	56	63	71	80	90	16
PPRB 16	13.01 – 16.00	32	40	45	50	56	63	71	80	90	19

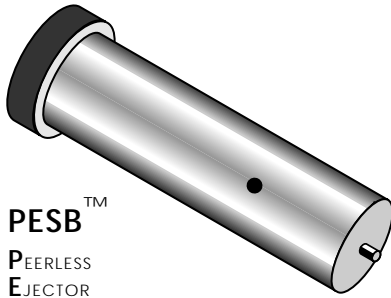

PESB™
 PEERLESS
 EJECTOR
 SHOULDER
 BLANKS

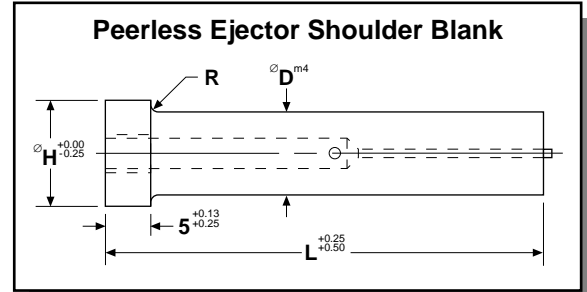

A2, R/c 59-61 double tempered
 M2, R/c 61-63 triple tempered
 PS, R/c 62-64 triple tempered

Heads drawn to Rc 40-55.

Ordering Example:
(12) PESB 8-45 A2

TYPE & "D"	OVERALL LENGTH "L"									HEAD DIA. "H"	EJECT. TYPE
	32	40	45	50	56	63	71	80	90		
PESB 5	32	40	45	50	56	63				8	E2AM
PESB 6	32	40	45	50	56	63	71	80		9	E3M
PESB 8	32	40	45	50	56	63	71	80		11	E4M
PESB 10	32	40	45	50	56	63	71	80	90	13	E6M
PESB 13		40	45	50	56	63	71	80	90	16	E6M
PESB 16		40	45	50	56	63	71	80	90	19	E9M
PESB 20		40	45	50	56	63	71	80	90	24	E9M
PESB 25		40	45	50	56	63	71	80	90	29	E9M

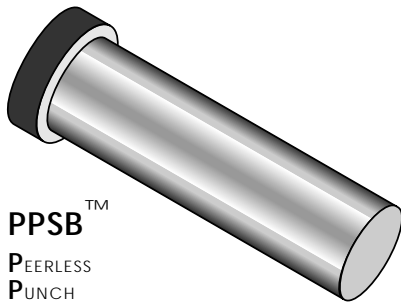

PPSB™
 PEERLESS
 PUNCH
 SHOULDER
 BLANKS

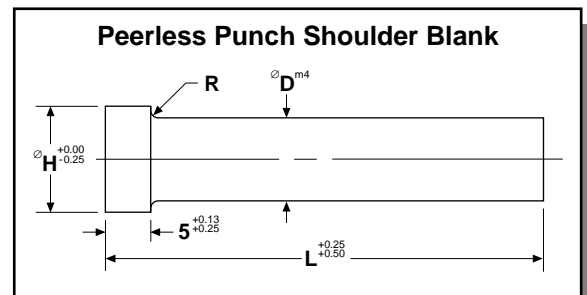

A2, R/c 59-61 double tempered
 M2, R/c 61-63 triple tempered
 PS, R/c 62-64 triple tempered

Heads drawn to Rc 40-55.

Ordering Example:
(9) PPSB 16-71 M2

TYPE & "D"	OVERALL LENGTH "L"															HEAD DIA. "H"
	32	40	45	50	56	63	71	80	90	100	110	125	140	150	175	
PPSB 4	32	40	45	50	56	63	71									7
PPSB 5	32	40	45	50	56	63	71	80								8
PPSB 6	32	40	45	50	56	63	71	80	90							9
PPSB 8	32	40	45	50	56	63	71	80	90	100						11
PPSB 10	32	40	45	50	56	63	71	80	90	100	110	125				13
PPSB 13		40	45	50	56	63	71	80	90	100	110	125	140	150		16
PPSB 16		40	45	50	56	63	71	80	90	100	110	125	140	150	175	19
PPSB 20					56	63	71	80	90	100	110	125	140	150	175	24
PPSB 25					56	63	71	80	90	100	110	125	140	150	175	29



PBPRTM
Peerless
Button
Press-Fit
Round



PBPOTM
Peerless
Button
Press-Fit
Oblong



PBPSTM
Peerless
Button
Press-Fit
Square/Rectangular



PBPHTM
Peerless
Button
Press-Fit
High Production

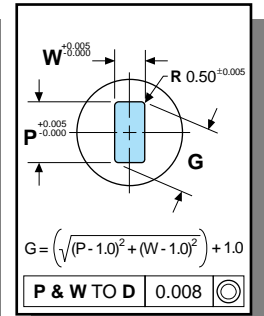
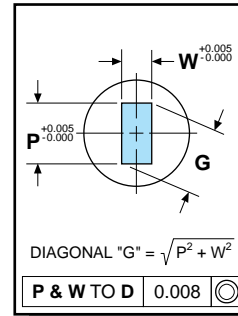
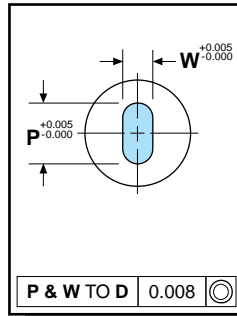
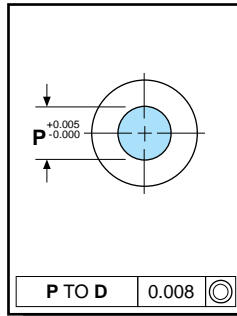
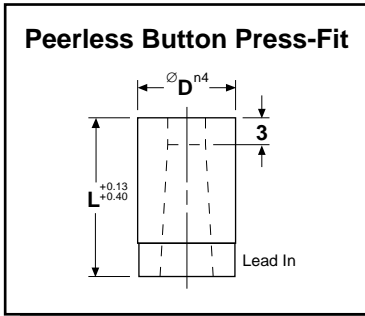

Ordering Examples:
(12) PBPR 20-32 A2 P10.3 K2
(18) PBPO 16-28 PS P7.7 W2.8 K4
(24) PBPS 13-25 M2 P6.1 W4.4 K4
(30) PBPH 10-22 M2 P6.2 W3.8 K2

A2, R/c 59-61 double tempered
M2, R/c 61-63 triple tempered
PS, R/c 62-64 triple tempered

Key-Flats in Die Position (See Pg. T9-10)

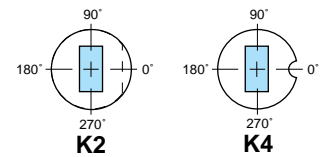

TYPE & "D"	MIN. "P"	MAX. "P"	TYPE & "D"	MIN. "W"	MAX. "P" or "G"	OVERALL LENGTH "L"							
						13	16	20	22	25	28	32	35
PBPR 5	1.6	3.2	PBP_ 5	1.0	3.2	13	16	20	22	25	28		
PBPR 6	1.6	3.9	PBP_ 6	1.0	3.9	13	16	20	22	25	28		
PBPR 8	2.4	5.4	PBP_ 8	1.0	5.4	13	16	20	22	25	28	32	
PBPR 10	3.2	6.8	PBP_ 10	1.0	6.8	13	16	20	22	25	28	32	35
PBPR 13	5.4	8.8	PBP_ 13	1.3	8.8	13	16	20	22	25	28	32	35
PBPR 16	7.4	10.8	PBP_ 16	1.9	10.8			20	22	25	28	32	35
PBPR 20	9.5	13.6	PBP_ 20	1.9	13.6			20	22	25	28	32	35
PBPR 25	12.0	17.0	PBP_ 25	1.9	17.0			20	22	25	28	32	35
PBPR 32	16.0	22.0	PBP_ 32	1.9	22.0			20	22	25	28	32	35
PBPR 40	18.0	26.0	PBP_ 40	1.9	26.0			20	22	25	28	32	35



PBSRTM
P
E
E
R
L
E
S
S
B
U
T
T
O
N
S
H
O
U
L
D
E
R
R
O
U
N
D



PBSOTM
P
E
E
R
L
E
S
S
B
U
T
T
O
N
S
H
O
U
L
D
E
R
O
B
L
O
N
G



PBSSTM
P
E
E
R
L
E
S
S
B
U
T
T
O
N
S
H
O
U
L
D
E
R
S
Q
U
A
R
E
/
R
E
C
T
A
N
G
U
L
A
R



PBSHTM
P
E
E
R
L
E
S
S
B
U
T
T
O
N
S
H
O
U
L
D
E
R
H
I
G
H
P
R
O
D
U
C
T
I
O
N

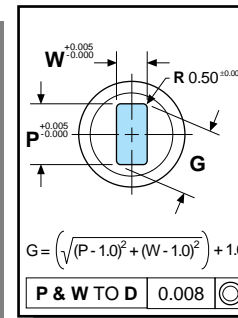
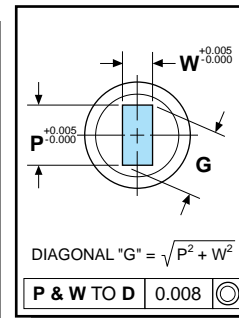
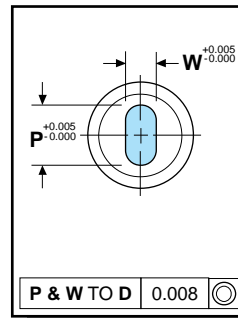
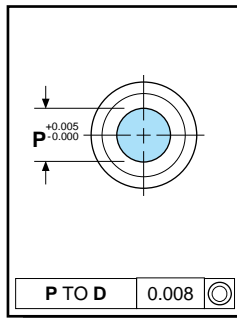
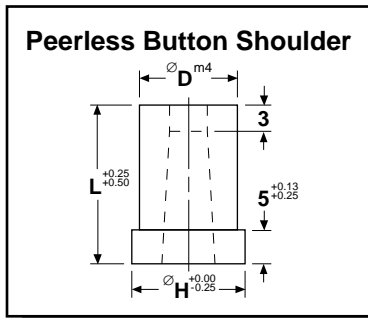

Ordering Examples:
(3) PBSR 5-20 M2 P2.9 K3
(6) PBSO 6-22 A2 P3.0 W2.0 K4
(9) PBSS 8-25 PS P3.7 W2.5 K2
(12) PBSH 10-28 M2 P5.5 W4.1 K2

A2, R/c 59-61 double tempered
M2, R/c 61-63 triple tempered
PS, R/c 62-64 triple tempered

Key-Flats in Die Position (See Pg. T9-10)

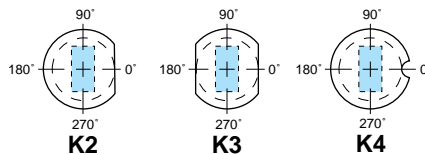

TYPE & "D"	MIN. "P"	MAX. "P"	TYPE & "D"	MIN. "W"	MAX. "P" or "G"	OVERALL LENGTH "L"								HEAD DIA. "H"
						13	16	20	22	25	28	32	35	
PBSR 5	1.6	3.2	PBS_ 5	1.0	3.2	13	16	20	22	25	28			8
PBSR 6	1.6	3.9	PBS_ 6	1.0	3.9	13	16	20	22	25	28			9
PBSR 8	2.4	5.4	PBS_ 8	1.0	5.4	13	16	20	22	25	28	32		11
PBSR 10	3.2	6.8	PBS_ 10	1.0	6.8	13	16	20	22	25	28	32	35	13
PBSR 13	5.4	8.8	PBS_ 13	1.3	8.8	13	16	20	22	25	28	32	35	16
PBSR 16	7.4	10.8	PBS_ 16	1.9	10.8			20	22	25	28	32	35	19
PBSR 20	9.5	13.6	PBS_ 20	1.9	13.6			20	22	25	28	32	35	24
PBSR 25	12.0	17.0	PBS_ 25	1.9	17.0			20	22	25	28	32	35	29
PBSR 32	16.0	22.0	PBS_ 32	1.9	22.0			20	22	25	28	32	35	36
PBSR 40	18.0	26.0	PBS_ 40	1.9	26.0			20	22	25	28	32	35	45

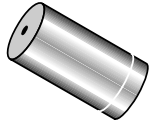

PBPPTM
P
EERLESS
B
UTTON
P
RESS-FIT
B
LANK

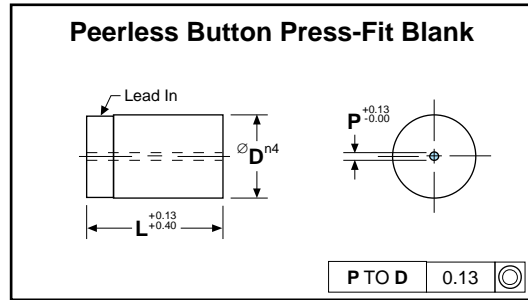

Ordering Example:
(15) PBPP 32-35 M2

TYPE & "D"	OVERALL LENGTH "L"								DRILL "P"
	13	16	20	22	25	28	32	35	
PBPP 5	13	16	20	22	25	28			0.8
PBPP 6	13	16	20	22	25	28			0.8
PBPP 8	13	16	20	22	25	28	32		0.8
PBPP 10	13	16	20	22	25	28	32	35	0.8
PBPP 13	13	16	20	22	25	28	32	35	0.8
PBPP 16			20	22	25	28	32	35	1.5
PBPP 20			20	22	25	28	32	35	1.5
PBPP 25			20	22	25	28	32	35	1.5
PBPP 32			20	22	25	28	32	35	1.5
PBPP 40			20	22	25	28	32	35	1.5

A2, R/c 59-61 double tempered
M2, R/c 61-63 triple tempered
PS, R/c 62-64 triple tempered

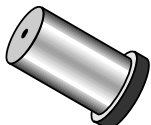

PBSBTM
P
EERLESS
B
UTTON
S
HOULDER
B
LANK

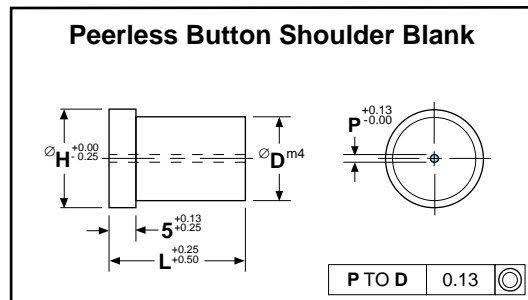

Ordering Example:
(12) PBSB 25-28 PS

TYPE & "D"	OVERALL LENGTH "L"								HEAD DIA. "H"	DRILL "P"
	13	16	20	22	25	28	32	35		
PBSB 5	13	16	20	22	25	28			8	0.8
PBSB 6	13	16	20	22	25	28			9	0.8
PBSB 8	13	16	20	22	25	28	32		11	0.8
PBSB 10	13	16	20	22	25	28	32	35	13	0.8
PBSB 13	13	16	20	22	25	28	32	35	16	0.8
PBSB 16			20	22	25	28	32	35	19	1.5
PBSB 20			20	22	25	28	32	35	24	1.5
PBSB 25			20	22	25	28	32	35	29	1.5
PBSB 32			20	22	25	28	32	35	36	1.5
PBSB 40			20	22	25	28	32	35	45	1.5

A2, R/c 59-61 double tempered
M2, R/c 61-63 triple tempered
PS, R/c 62-64 triple tempered



PGP_{TM}
 PEERLESS
 GUIDE BUSHINGS
 PRESS-FIT
 — (R, O or S)

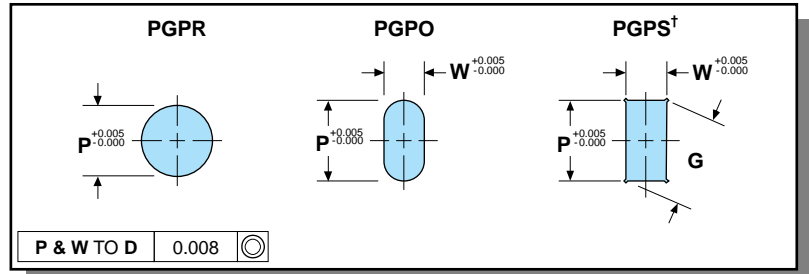
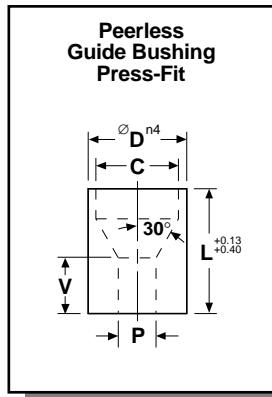

TYPE & "D"	MIN. "P"	MAX. "P"	TYPE & "D"	MIN. "W"	MAX. "P" or "G"	OVERALL LENGTH "L"				"C"
						8	10	13	16	
PGPR 5	1.6	3.2	PGP_ 5	1.0	3.2	8	10	13	16	3.6
PGPR 6	1.6	3.9	PGP_ 6	1.0	3.9		10	13	16	4.6
PGPR 8	2.4	5.4	PGP_ 8	1.0	5.4		10	13	16	6.6
PGPR 10	3.2	6.8	PGP_ 10	1.0	6.8		10	13	16	8.2
PGPR 13	5.4	8.8	PGP_ 13	1.3	8.8			13	16	11.4
PGPR 16	7.4	10.8	PGP_ 16	1.9	10.8				16	Variable*

Ordering Example:
(9) PGPS 8-13 A2 P3.2 W2.1

A2, R/c 59-61 double tempered
 * See **Guide Bushing Length ("V")** below.
 † See **Guide Bushing Corners** below.

Guide Bushing Length ("V")

The guide bushing hole's contour, as reflected in "V" and "C," depends on the relationship of "P," "D" and "L." As "P" increases, "V" increases and "C" decreases. When "D" and "L" are large this can result in a hole that's all countersink.

HOLE "P"	LAND "V"
≤ 1.70	2P
1.70 to 2.40	P + 1.70
2.40 to 10.80	.82P + 2.10

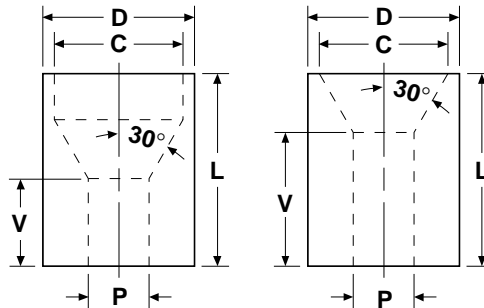

Guide Bushing Corners

Lane Peerless Guide Bushings with rectangular, square or similar special shapes are engineered with overcut corners to avoid interference. Four point contact assures smooth, accurate guiding and less fitting by the die maker.





PGDTM
PEERLESS
GUIDE BUSHINGS
DOWNHEAD
_ (R, O or S)

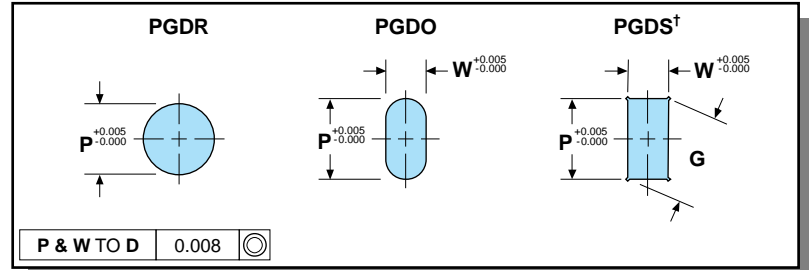
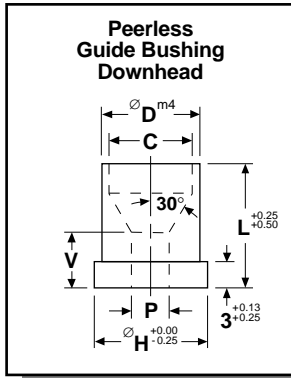

Ordering Example:
(24) PGDS 6-16 A2 P2.9 W1.4

A2, R/c 59-61 double tempered.

Key-flat options are those shown on page PS1.

* See Guide Bushing Length ("V") on page PS10.

† See Guide Bushing Corners on page PS10.

TYPE & "D"	MIN. "P"	MAX. "P"	TYPE & "D"	MIN. "W"	MAX. "P" or "G"	OVERALL LENGTH "L"				"C"	HEAD DIA. "H"
						8	10	13	16		
PGDR 5	1.6	3.2	PGD_ 5	1.0	3.2	8	10	13		3.6	8.0
PGDR 6	1.6	3.9	PGD_ 6	1.0	3.9		10	13	16	4.6	9.0
PGDR 8	2.4	5.4	PGD_ 8	1.0	5.4		10	13	16	6.6	11.0
PGDR 10	3.2	6.8	PGD_ 10	1.0	6.8		10	13	16	8.2	13.0
PGDR 13	5.4	8.8	PGD_ 13	1.3	8.8			13	16	11.4	16.0
PGDR 16	7.4	10.8	PGD_ 16	1.9	10.8				16	Variable*	19.0



PGUTM
PEERLESS
GUIDE BUSHINGS
UPHEAD
_ (R, O or S)

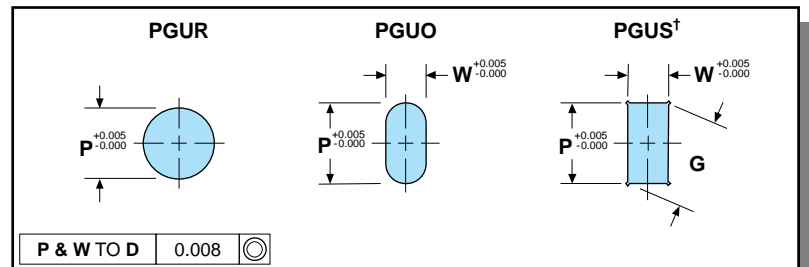
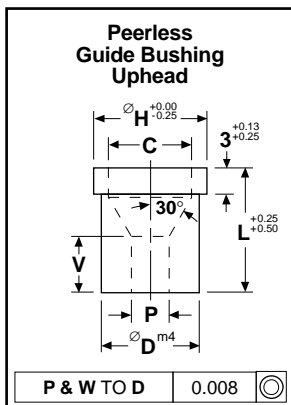

Ordering Example:
(30) PGUO 5-8 A2 P1.8 W1.1

A2, R/c 59-61 double tempered.

Key-flat options are those shown on page PS1.

* See Guide Bushing Length ("V") on page PS10.

† See Guide Bushing Corners on page PS10.

TYPE & "D"	MIN. "P"	MAX. "P"	TYPE & "D"	MIN. "W"	MAX. "P" or "G"	OVERALL LENGTH "L"				"C"	HEAD DIA. "H"
						8	10	13	16		
PGUR 5	1.6	3.2	PGU_ 5	1.0	3.2	8	10	13		3.6	8.0
PGUR 6	1.6	3.9	PGU_ 6	1.0	3.9		10	13	16	4.6	9.0
PGUR 8	2.4	5.4	PGU_ 8	1.0	5.4		10	13	16	6.6	11.0
PGUR 10	3.2	6.8	PGU_ 10	1.0	6.8		10	13	16	8.2	13.0
PGUR 13	5.4	8.8	PGU_ 13	1.3	8.8			13	16	11.4	16.0
PGUR 16	7.4	10.8	PGU_ 16	1.9	10.8				16	Variable*	19.0

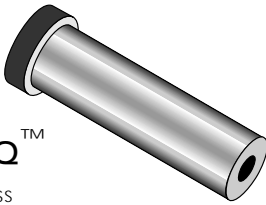

PHBQ™
 PEERLESS
 HOLDER
 BEVELED
 QUILL

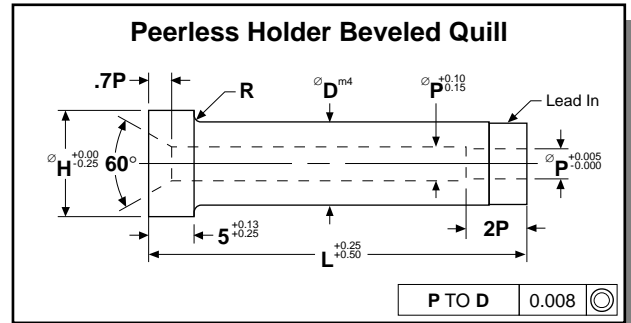

A2, R/c 59-61 double tempered

Ordering Example:
(18) PHBQ 10-32 A2

TYPE & "D"	LENGTH "L"			"P"	HEAD DIA. "H"
	20	25	32		
PHBQ 5	20	25	32	2	8
PHBQ 6	20	25	32	3	9
PHBQ 8	20	25	32	4	11
PHBQ 10	20	25	32	5	13
PHBQ 13	20	25	32	6	16

Peerless Quill Punch Bevel Blanks™ Peerless Quill Punch Shoulder Blanks™

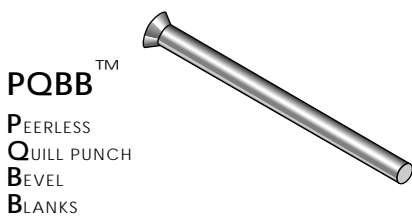

PQBB™
 PEERLESS
 QUILL PUNCH
 BEVEL
 BLANKS

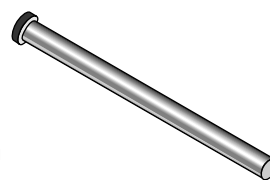

PQSB™
 PEERLESS
 QUILL PUNCH
 SHOULDER
 BLANKS

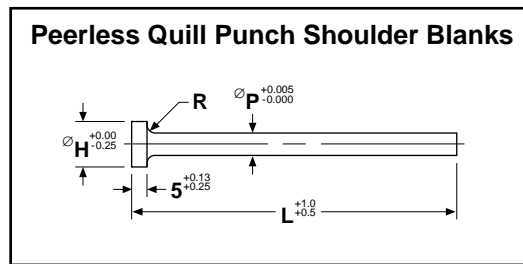
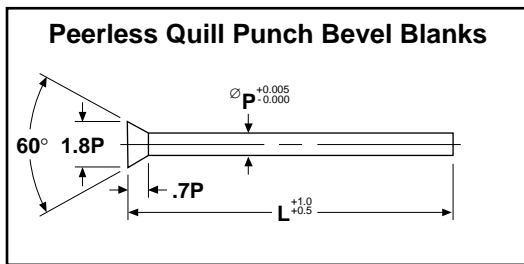

M2, R/c 61-63 triple tempered

Ordering Examples:
(6) PQBB 3-40 M2 P2.72
(9) PQSB 4-50 M2 P3.29

TYPE & "D"	TYPE & "D"	OVERALL LENGTH "L"					"P"	PQSB "H"
		40	45	50	56	63		
PQBB 2	PQSB 2	40	45	50	56	63	0.81 – 2.00	4
PQBB 3	PQSB 3	40	45	50	56	63	2.01 – 3.00	5
PQBB 4	PQSB 4	40	45	50	56	63	3.01 – 4.00	6
PQBB 5	PQSB 5	40	45	50	56	63	4.01 – 5.00	7
PQBB 6	PQSB 6	40	45	50	56	63	5.01 – 6.00	8
PQBB 7	PQSB 7	40	45	50	56	63	6.01 – 7.00	9

PQBR™
PEERLESS
QUILL PUNCH
BEVEL
ROUND

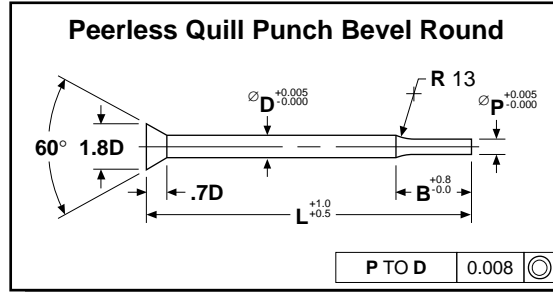
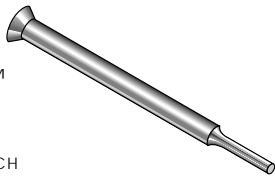

M2, R/c 61-63 triple tempered

TYPE & "D"	OVERALL LENGTH "L"					"P"	"B"
	40	45	50	56	63		
PQBR 2	40	45	50	56	63	0.81 – 2.00	5
PQBR 3	40	45	50	56	63	2.01 – 3.00	7
PQBR 4	40	45	50	56	63	3.01 – 4.00	8
PQBR 5	40	45	50	56	63	4.01 – 5.00	8
PQBR 6	40	45	50	56	63	5.01 – 6.00	8
PQBR 7	40	45	50	56	63	6.01 – 7.00	8

Ordering Examples:
(18) PQBR 5-45 M2 P4.43

PQSR™
PEERLESS
QUILL PUNCH
SHOULDER
ROUND

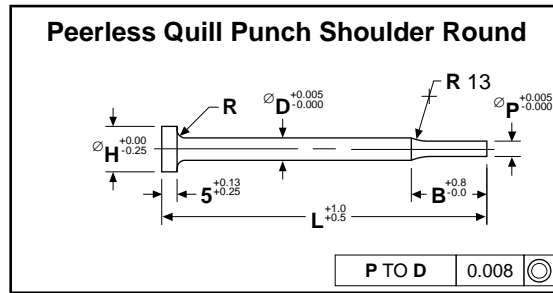
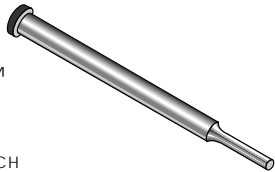

M2, R/c 61-63 triple tempered

TYPE & "D"	OVERALL LENGTH "L"					"P"	"B"	HEAD DIA. "H"
	40	45	50	56	63			
PQSR 2	40	45	50	56	63	0.81 – 2.00	5	4
PQSR 3	40	45	50	56	63	2.01 – 3.00	7	5
PQSR 4	40	45	50	56	63	3.01 – 4.00	8	6
PQSR 5	40	45	50	56	63	4.01 – 5.00	8	7
PQSR 6	40	45	50	56	63	5.01 – 6.00	8	8
PQSR 7	40	45	50	56	63	6.01 – 7.00	8	9

Ordering Examples:
(36) PQSR 6-56 M2 P5.67